

DESCRIPTION

The Type-100 is a high precision, multi-stage pressure regulator. This pressure controller provides the highest level of regulation accuracy and repeatability available. The Type-100 is ideal for applications that call for the utmost in control and maximum stability under variable operating conditions. A stainless steel measuring capsule is used as a sensing element to activate the high gain servo balanced control mechanism in which the main valve is controlled by a pilot valve. This allows for greater accuracy and eliminates many of the problems associated with conventional regulators using range springs and diaphragms.

FEATURES

- **ACCURATE PRESSURE REGULATION** - The ControlAir Type-100 regulator controls output pressure to within 0.1% accuracy. Regulated pressure variation as small as 0.01 psig is self corrected.
- **STABLE OUTPUT** - This regulator is very insensitive to changes in supply pressure and flow. Substantial changes in flow have virtually no effect on regulated pressure from dead end to 12 SCFM.
- **DEPENDABLE STARTUP** - After long "down time" the Type-100 will start up and return the regulated pressure to its original output setting.
- **HIGH RELIEF CAPACITY** - The Type-100HR is available with an optional high relief capacity. A high flow relief valve provides quick response whenever the regulated pressure is reset to a lower value or when there is a large amount of system back pressure to be relieved.
- **TEMPERATURE STABILITY** - Effects on regulated pressure by wide variations in operating temperature are minimized through the use of a stainless steel measuring capsule which activates the servo-control mechanism.
- **LOCKING CAPABILITY** - Standard units of the Type-100 include a locking nut which when tightened prevents inadvertent pressure adjustment.

MODELS

Type-100 - Standard regulator is offered in three pressure ranges (2-40 psi, 2-60 psi, 2-120 psi) and with choice of three porting sizes (1/8", 1/4", 3/8").

Type-100HR - High relief capacity allows for quick "blow-down" capability for rapid exhaust of output pressure.

Type-100LR - Low range capability provides accurate pressure regulation at lower output range. Note: Maximum supply pressure 50 psig.

Type-100PL - Plunger operated version controls regulated pressure by linear actuation of the plunger rather than manual adjustment of the knob.

Type-100BP - Bottom ported supply and output pressure allows manifold mounting of regulators. Suitable for applications with limited space.

Motorized T-100M - Motorized regulator. Consult factory for information.

APPLICATIONS

The Type-100 is well suited for any process that requires very precise regulation of air pressure in pipes and vessels. The Type-100 is often used, but not limited to the following applications:

Air Gauging	Air Hoists	Roll Loading
Gas Mixing	Web Tensioning	Valve Operators
Calibration Standards	Gate Actuators	Cylinder Loading



TYPE 100 PRECISION AIR
PRESSURE REGULATOR

TYPE 100 PRECISION AIR PRESSURE REGULATOR

PRINCIPLE OF OPERATION

The measuring capsule in the Type-100 is the sensing element that controls a high precision, balanced servomechanism. A special stainless steel alloy construction gives the measuring capsule the ability to maintain forces over long periods of time without hysteresis. This eliminates problems associated with regulators that are controlled by a range spring.

The downstream regulated pressure fills the control chamber and surrounds the measuring capsule. Expansion, contraction, or other slight movement of the capsule causes the pilot valve to open or close. This creates a substantial pressure change within the pilot pressure chamber. The change in pilot pressure is directly proportional to the downward force on the pilot diaphragm which causes the appropriate movement of the supply valve or relief valve and corrects any variation from set pressure. The high gain nature of this servomechanism allows the Type-100 to react to changes in set pressure as little as 0.01 psig.

Regulated pressure applies an upward force on the underside of the control diaphragm. When set pressure drifts above the set point the control diaphragm assembly moves upward and allows excess pressure to be vented out of the relief valve to atmosphere. The design of the relief valve permits substantial reverse flow capacity which quickly exhausts system back pressure thus eliminating the need for a separate relief valve.

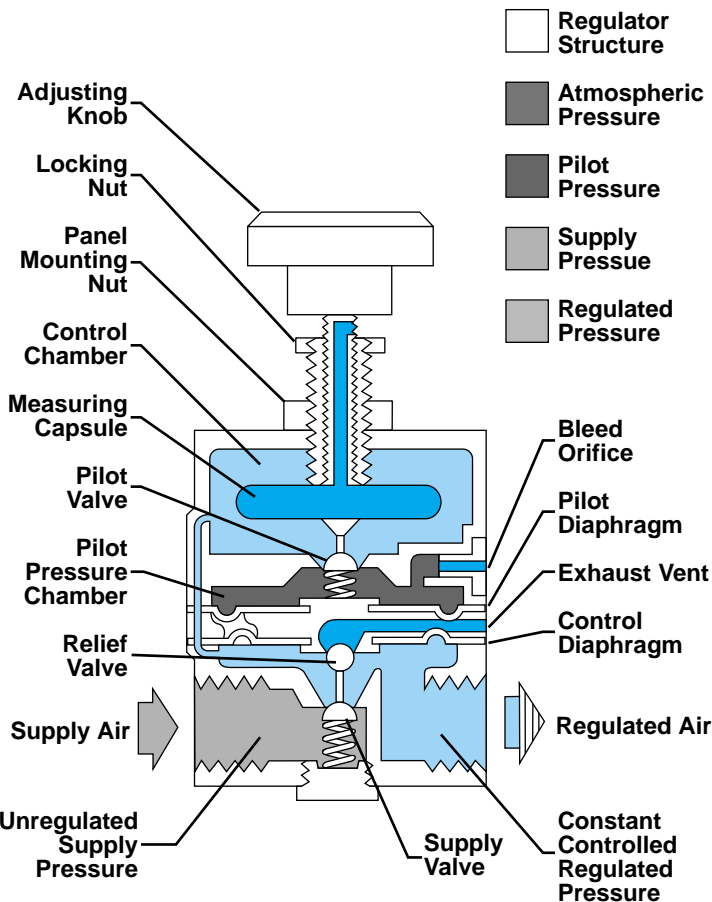

SPECIFICATIONS

- Flow Capacity**14 SCFM (25m³/hr.) at 100 psig (700 kPa) supply - 20 psig (140 kPa) outlet
- Exhaust Capacity**5 psig (35 kPa) above 20 psig (140 kPa) setpoint
 - Type 1003 SCFM (3.4 m³/hr.)
 - Type 100 HR (High Relief)11 SCFM (17.0 m³/hr.)
- Sensitivity**1/8" (3.2 mm) water
- Pilot Pressure Chamber**
 - Bleed Rate**less than 0.08 SCFM (0.15m³/hr.)
- Total Air Consumption**6 SCFH (.21m³/hr.)
- Effect of Supply Pressure Variation** of 25 psig (170 kPa) on outlet
 - Less than .005 psig (0.3 kPa)
- Supply Pressure, Maximum**150 psig (1050 kPa)
- Materials:** Body; *diecast zinc alloy*. Capsule and adjusting screw; *stainless steel*. Assemblies; *stainless steel, brass, plated steel, acetal*. Diaphragms; *Buna-N elastomer and polyester fabric*. Knob; *phenolic plastic*.
- Weight**1.4 lb (635 g)
- Port Sizes**1/8", 1/4", 3/8"
- Gage Ports (2)**1/4"

FLOW CHARACTERISTICS

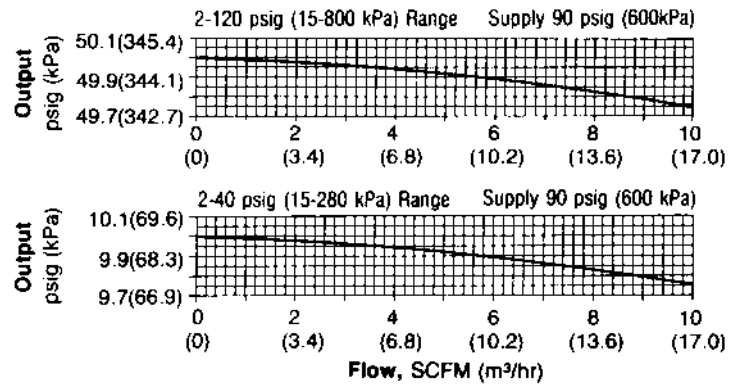

OPTIONS

- Pressure Gauge** - to order unit with a pressure gauge add a **G** to end of part number. Gauge is 2 in. (50.8 mm) diameter face, 1/4 NPT back connection.
- Tamperproof Cover** - to order with tamperproof cover add a **T** to end of part number. See drawing for dimensions.
- Bracket** - to order with bracket add a **B** to end of part number.
- Preset Pressure** - Output pressure can be preset at factory. Consult factory for ordering information.
- Tapped Exhaust** - to order with a 10-32 tapped exhaust vent and barbed bleed screw add an **E** to end of part number.
- Oxygen Compatible** - consult factory for ordering information

TYPE-100 REGULATOR

The standard Type-100 regulator is available in three output ranges and three port sizes.

TYPE-100 HR HIGH RELIEF REGULATOR

In addition to offering all of the features of the Type-100 regulator, this unit allows fast exhaust of downstream pressure. The ability to quickly relieve system back pressure makes the Type-100HR ideal for any pneumatic counterbalance application.

TYPE-100LR LOW RANGE REGULATOR

For applications that require output pressure below the standard 2.0 psig, the Type-100LR operates with an output pressure range of 0.5 psig to 25 psig. Maximum supply pressure is 50 psig.

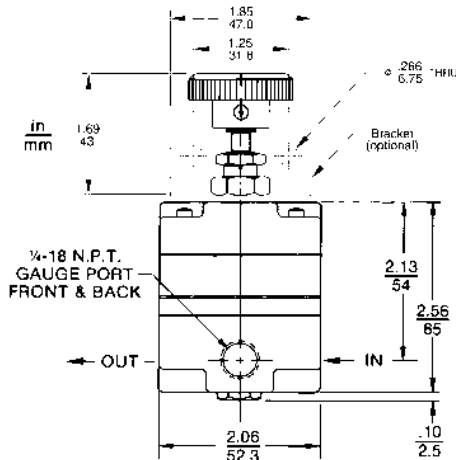

1/2" (12.7 mm) dia. hole for panel mounting; max. panel thickness, 1/2" (12.7 mm)

TYPE-100PL PLUNGER OPERATED REGULATOR

Regulated output pressure is controlled by direct linear actuation of the plunger rather than turning a knob.

PLUNGER TRAVEL

Pressure Range		Plunger Travel*	
psig	kPa	in	mm
2-40	15-280	.120	3.0
2-60	15-400	.090	2.3
2-120	15-800	.100	2.5

* +/- 10% manufacturer tolerance

RETURN SPRING

0.4 in. (10 mm) nominal return height; 7 oz. (200 g) approximate preload force. 7.5 lb./in. (135 g/mm) approximate

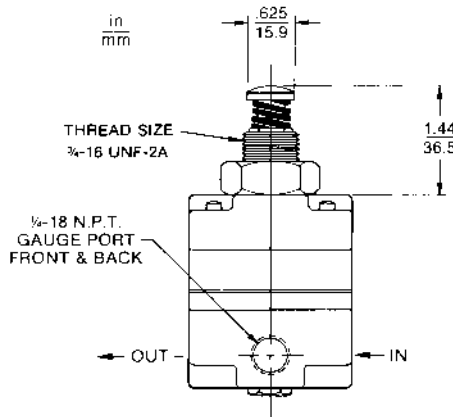

TYPE-100BP BOTTOM PORTED REGULATOR

Manifold mounting is available by using the bottom ported version of the regulator. The Type-100BP comes complete with "In" and "Out" ports on the bottom of the regulators, as well as four tapped mounting holes.

TAMPERPROOF COVER

The Type-100BP is shown with the optional tamperproof cover. The tamperproof cover is available with the

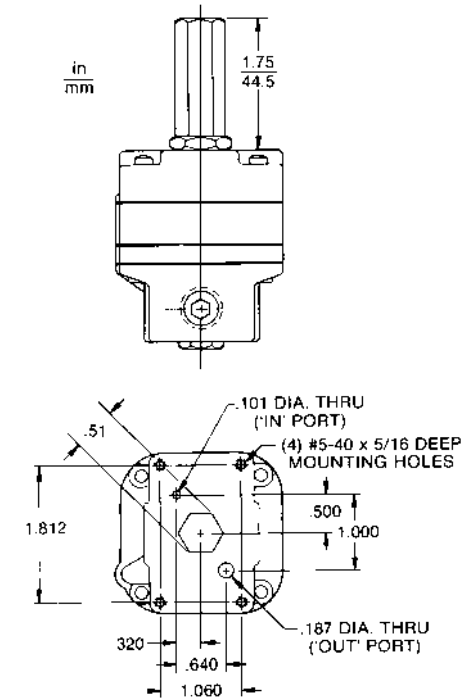

Type	Part Number	Port Size (NPT)	Output Range	
			psi	kPa
100	100-AA	1/8"	2-40	15-280
100	100-AB	1/8"	2-60	15-400
100	100-AC	1/8"	2-120	15-800
100	100-BA	1/4"	2-40	15-280
100	100-BB	1/4"	2-60	15-400
100	100-BC	1/4"	2-120	15-800
100	100-CA	3/8"	2-40	15-280
100	100-CB	3/8"	2-60	15-400
100	100-CC	3/8"	2-120	15-800
100HR	110-BC	1/4"	2-120	15-800
100HR	110-CC	3/8"	2-120	15-800
100LR	120-BA	1/4"	.5-25	5-175

Type	Part Number	Port Size (NPT)	Output Range	
			psi	kPa
100BP	140-BA	-	2-40	15-280
100BP	140-BB	-	2-60	15-400
100BP	140-BC	-	2-120	15-800
100PL	150-AA	1/8"	2-40	15-280
100PL	150-AB	1/8"	2-60	15-400
100PL	150-AC	1/8"	2-120	15-800
100PL	150-BA	1/4"	2-40	15-280
100PL	150-BB	1/4"	2-60	15-400
100PL	150-BC	1/4"	2-120	15-800
100PL	150-CA	3/8"	2-40	15-280
100PL	150-CB	3/8"	2-60	15-400
100PL	150-CC	3/8"	2-120	15-800

OTHER PRODUCTS FROM CONTROLAIR



**Type-100
Precision Air
Pressure Regulator**
This compact unit controls output pressure to within 0.1% accuracy.



**Type-100M
Motorized Air
Pressure Regulator**
This accuracy of the Type-100 in combination with electric control.



**Type-200
Precision
Biasing Relay**
Signal operated regulator that provides very precise control of output pressure with positive and negative biasing capability.



**Type-300
Instrument Air
Filter Regulator**
Economical alternative for providing clean, regulated air to instruments, valves and other automatic control equipment.



**Type-350SS
Stainless Steel
Filter Regulator**
Designed to provide instrument quality air in corrosive environments.



**Type-400
General Service
Regulator**
High regulation performance at low cost.



**Type-500X
Electropneumatic
Transducer (I/P, E/P)**
Converts a current or voltage input signal to a linearly proportional pneumatic output pressure.



**Type-600
Ratio Relay
Volume Booster**
Uses a pneumatic signal to produce an output pressure which has high flow capacity and can be amplified.



**Type-700
High Flow
Capacity
Precision Air
Pressure
Regulator**
Flows up to 80 SCFM with minimum droop.



**Type-700BP
Precision Back
Pressure
Regulator**
Operates as a high flow capacity, quick response relief valve with an adjustable set point.



**Type-800
Subminiature
Precision Air
Pressure
Regulator**
Compact unit provides high precision pressure regulation for applications where space is limited.



**Type-850/860
Miniature
Air/Water
Pressure
Regulator**
General service regulator provides stable output pressure in a small, economical package.



**Type-900X
Electropneumatic
Transducer (I/P, E/P)**
Internal feedback system provides accurate conversion of a variable electrical signal to a linearly proportional pneumatic signal.



**Type-950XP
Explosion Proof
Transducer (I/P)**
Compact I/P transducer in an explosion-proof housing delivers reliable performance for hazardous areas.

Diaphragm Air Cylinders

Provides virtually frictionless conversion of fluid pressure to linear mechanical force. Utilizes a rolling diaphragm for a low hysteresis, no blow by positive seal.



Custom Pneumatic Devices

ControlAir designs and manufactures custom devices usually incorporating the performance advantages of rolling diaphragm seals

LIMITED WARRANTY & DISCLAIMER

ControlAir, Inc. products are warranted to be free from defects in materials and workmanship for a period of eighteen months from the date of sale, provided said products are used according to ControlAir, Inc. recommended usages. ControlAir, Inc.'s liability is limited to repair of, refund of purchase price paid for, or replacement in kind of, at ControlAir, Inc.'s sole option, any products proved defective. ControlAir, Inc. reserves the right to discontinue manufacture of any products or change product materials, designs or specifications without notice.

WARNING

These products are intended for use in industrial compressed-air systems only. Do not use these products where pressures and temperatures can exceed those listed under Specifications. Before using these products with fluids other than air, for nonindustrial application, life-support systems, or other applications not within published specifications, consult ControlAir, Inc.

APPLICATION AND ENGINEERING ASSISTANCE

ControlAir engineers are always available to provide answers to any question that you might have about product performance or applications. We encourage you to give us a call at (603) 886-9400.



8 Columbia Drive, Amherst, NH 03031 USA • 603-886-9400 • FAX 603-889-1844
Website: <http://www.controlair.com> • Email: sales@controlair.com